

## USER MANUAL

---

### Three-Phase Grid-Tied Solar Inverter

30K/40K/50K/60K

## History

VERSION	ISSUED	COMMENTS
1.0	15-Jun.-23	First release
1.1	15-Nov.-23	Updated <a href="#">bracket</a> in <a href="#">3.1 Packing</a> and <a href="#">4.2 Mounting</a> .

## Preface

### About This Manual

This manual describes the installation, connection, the use of APP, commissioning and maintenance etc. of the inverter. Please first read the manual and related documents carefully before using the product, and be sure to store it in a place within the reach of installation, operation and maintenance personnel. The illustrations in this Manual are for reference only. This Manual is subject to change without prior notice. (Specific products in kind prevail.)

### Target Group

Inverters must be installed by qualified and professional electrical engineers.

### Scope

#### Natural cooling series

SE-TH02 30.0TL3

#### Fan cooling series





SE-TH01 40.0TL3

SE-TH01 50.0TL3

SE-TH01 60.0TL3

### Conventions

The following safety instructions and general information are used within this Manual.

 <b>DANGER</b>	Indicates an imminently hazardous situation which, if not correctly followed, will result in serious injury or death.
 <b>WARNING</b>	Indicates a potentially hazardous situation which, if not correctly followed, will result in serious injury or death.
 <b>CAUTION</b>	Indicates a potentially hazardous situation which, if not correctly followed, could result in moderate or minor injury
 <b>NOTICE</b>	Indicates a potentially hazardous situation which, if not correctly followed, could result in equipment failure, or property damage.
 <b>NOTE</b>	Call attention to important information, best practices and tips: supplement additional safety instructions for your better use of the inverter to reduce the waste of you resource

# CONTENTS

## **Preface**

- About This Manual
- Target Group
- Scope
- Conventions

## **1. Safety**

- 1.1 Symbols Used
- 1.2 Safety Precautions

## **2. Product Introduction**

- 2.1 Overview
- 2.2 Product Appearance

## **3. Unpacking and Storage**

- 3.1 Unpacking and Check
- 3.2 Storage Inverter
- 3.3 Identify Inverter

## **4. Installation**

- 4.1 Selecting the Mounting Location
- 4.2 Mounting

## **5. Electrical Connections**

- 5.1 Grounding
- 5.2 AC Connection
- 5.3 PV Connection
- 5.4 Communication Connection

## **6. Startup/Shutdown Procedure**

6.1 Inspection

6.2 Startup Procedure

6.3 Shutdown Procedure

## **7. User Interface**

7.1 LED

7.2 LCD

## **8. Troubleshooting and Maintenance**

8.1 Inverter Troubleshooting









8.2 Maintenance

## **9. Technical Specifications**

# 1 Safety

Before using the inverter, please read all instructions and cautionary markings on the unit and in this Manual. Put this Manual in a place where you can take it easily. Our inverter strictly conforms to related safety rules on design and test. Please follow local laws and regulations during installation, operation and maintenance. Incorrect operation may cause personal injury or death and damage.

## 1.1 Symbols Used

Safety Symbol	Description
	Danger of high voltage! Only qualified personnel may perform work on the inverter.
	Residual voltage exists after the inverter is powered off. It takes 30 minutes for system to discharge to a safe voltage.
	Danger of hot surface
 Do not disconnect under load!	Do not disconnect under load, otherwise there will be a danger of fire.
	Environmental Protection Use Period
	Refer to the operating instructions
	Don't dispose of the inverter with the household waste.
	Grounding terminal

## 1.2 Safety Precautions

- Installation, maintenance and connection of inverters must be performed by qualified personnel, in compliance with the electrical standards, wiring rules and requirements of local power authorities and/or companies.
- To avoid electric shock, DC input and AC output of the inverter must be terminated at least 10 minutes before performing any installation or maintenance.
- The temperature of some parts of the inverter may exceed 60°C during operation. so do not touch the inverter during operation, otherwise you may be burnt.
- Ensure children are kept away from the inverter.
- Take appropriate measures to avoid electric shock.
- Don't open the front cover of the inverter. Unless performing work at the wiring terminal (as instructed in this Manual), touching or changing components without authorization may cause personal injury, damage to inverter and annulment of the warranty.
- Ensure the output voltage of the proposed PV array is lower than the maximum rated input voltage of the inverter; otherwise the inverter may be damaged and the warranty annulled.
- When exposed to sunlight, the PV array will generate dangerous high DC voltage. So please operate it according to our instructions, or your life will be in danger.
- Do not insert or pull the AC and DC terminals when the inverter is running.

## 2 Product Introduction

### 2.1 Overview

The three-phase grid-tied solar inverter converts the direct current (DC) generated by PV panels into three-phase alternating current (AC) and is delivered to the grid.

This series of inverter is an important part of PV system and it is suitable for household use, commercial roof, fishing light, and agricultural light and more scenarios.

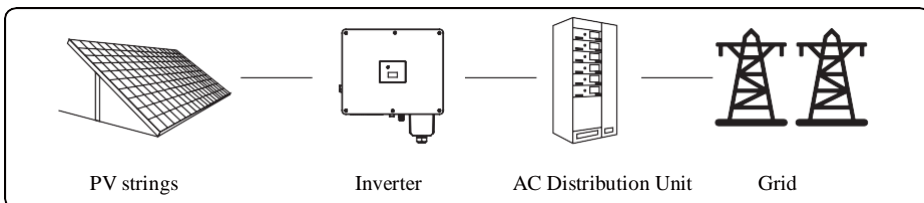

The inverter supports five types of earthing system, including TN-S, TN-C, TN-C-S, TT, IT.

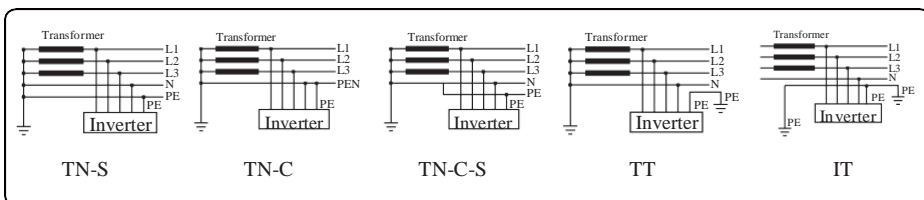

### 2.2 Product Appearance

The following figures are only for reference, specific products in kind prevail.

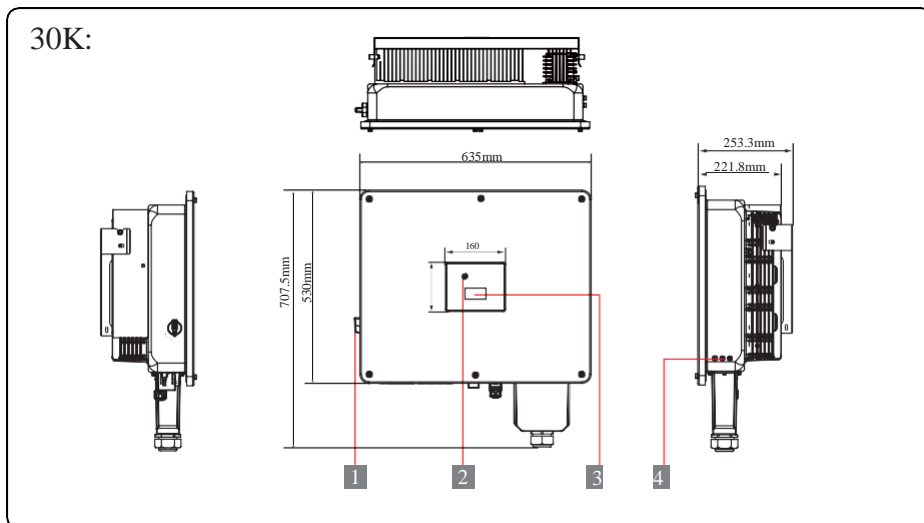



50K:

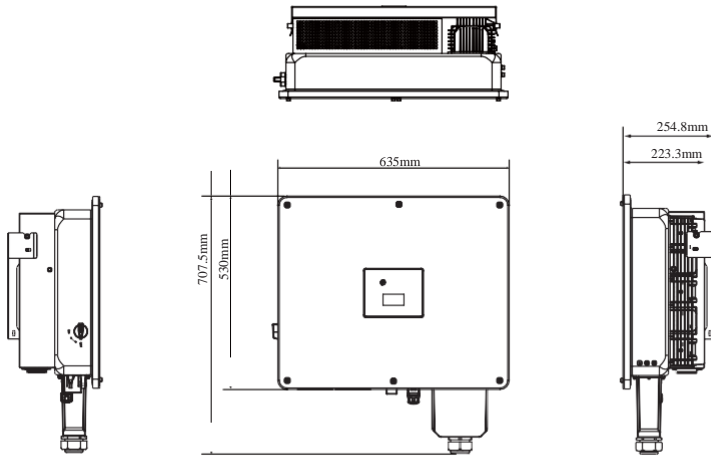

60K:

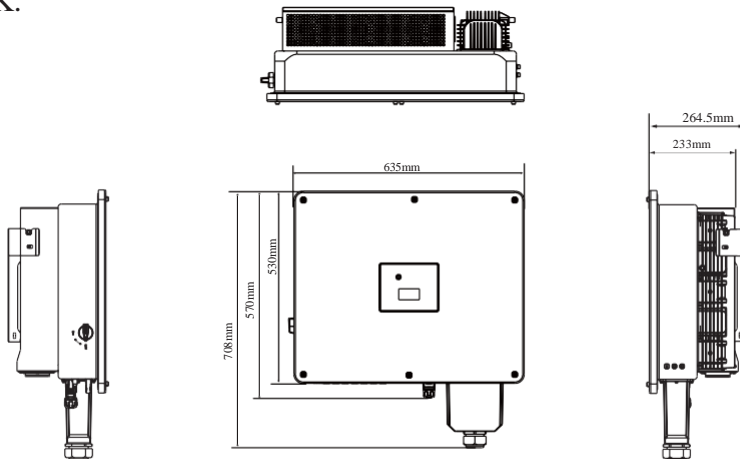

Product Introduction

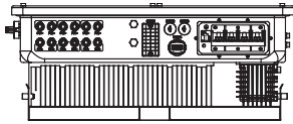

Natural cooling series

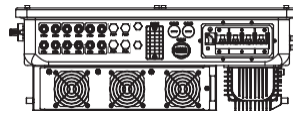

Fan cooling series 1

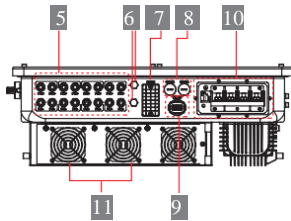

Fan cooling series 2

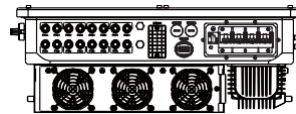

Fan cooling series 3

Number	Description
1	DC Switch
2	LED indicator
3	LCD Screen (optional)
4	External ground points
5	PV terminal
6	Vent valve
7	WIFI module communication port (COM1)
8	Reserved communication port (COM2/3)
9	RS485 communication port (COM4)
10	AC output port
11	External fan (It is only suitable for Fan cooling series)

## 3 Unpacking and Storage

### 3.1 Unpacking and Check

Complete test and strict inspection before the inverter is sent out.

When receiving the inverter, check that the packing materials are intact.

After unpacking, examine the PV inverter and its fittings for damage and check that the deliverables are complete.

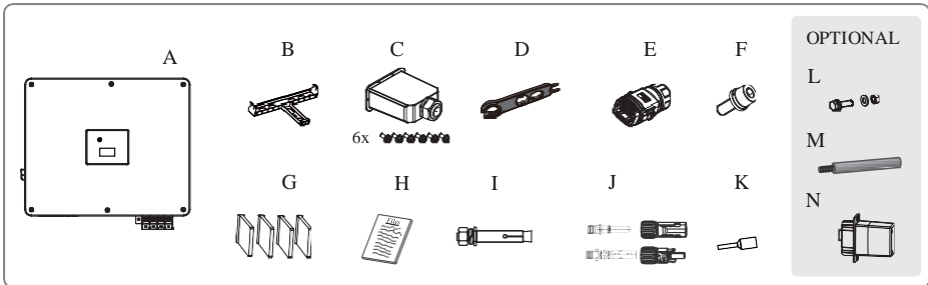

Number	Description	Quantity
A	Inverter	1
B	Wall mounting bracket	1
C	AC cover (with 6x M4 security screws)	1
D	Tightening/Removal tool for PV connector	1
E	RS485 terminal	1
F	M6 Security screws	2
G	AC inserting pieces	4
H	File package	2
I	M12 Expansion screws	3
J	PV connector groups	6 or 8
K	Pin terminal	12
L	M12 screws (only for bracket-mounted installation)	3 (optional)
M	Handle tool	2 (optional)
N	WIFI/GPRS/4G module	1 (optional)



**NOTICE**

Contact your dealer immediately, if there is any issue found during operation.

### 3.2 Storage Inverter

If the inverter is not used immediately, please keep the inverter in a specific environment according to the following:

- Do not unpack the inverter and put desiccant in the original box if the PV inverter is unpacked.
- Store temperature range:  $-25^{\circ}\text{C} \sim +60^{\circ}\text{C}$ ; Relative humidity range: 0~100%.
- When the inverter is placed multi-layered, it can be folded up to four layers.
- Do not position the inverter at a front tilt, excessive back tilt, or side tilt, or upside down.
- Ensure that qualified personnel inspect and test the inverter before use if it has been stored for a long time.

### 3.3 Identify Inverter

Inverter body label. The following is only for reference, specific please in kind prevail!

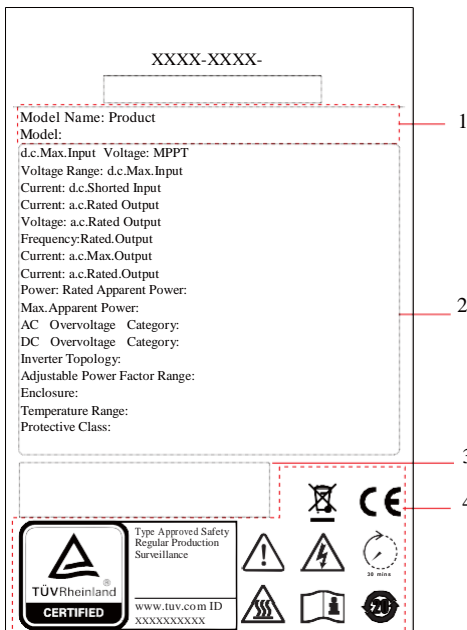

Number	Description
1	Product name and model
2	Product technical parameters
3	SN Barcode
4	Approve and Safety identification

## 4 Installation

After checking the outer packing, move the PV inverter to the designated installation position horizontally.

<p><b>CAUTION</b></p>	<p>1. Please place the inverter horizontally on the foam or other soft pads and ensure that the ports are free of load-bearing pressure to avoid inverter damages or scratches.</p> <p>2. The inverter is heavy, be careful to prevent the inverter from slipping and hurting the operator when moving the inverter.</p>
-----------------------	--

<p><b>DANGER</b></p>	<p>Ensure there is no electrical connections around ports of the PV inverter before installation.</p>
----------------------	---



**NOTE:**

The following figures only illustrate the appearance of 50K inverter as an example. Other inverter models' appearances will be marked if there are specific descriptions.

### 4.1 Selecting the Mounting Location

#### 4.1.1 Installation Environment Requirements

- a. With an IP66 protection rating, the inverter can be mounted either indoors or outdoors.
- b. To ensure optimum operation and a long service life, the ambient temperature must be below 50°C.
- c. Do not install the inverter in a rest area since it will cause noise during operation.
- d. The carrier where the inverter is mounted must be fire-proof. Do not mount the inverter on flammable building materials.
- e. Ensure that the wall meets the requirements of the inverter installation.
- f. Product label and warning symbols shall be clear to read after installation.
- g. The installation height should be reasonable, and make sure it is easy to operate and view the display.
- h. Please avoid direct sunlight, rain exposure, snow cover.

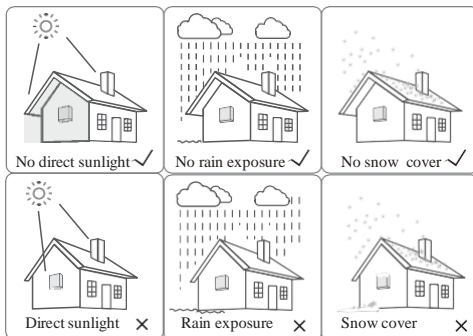

### 4.1.2 Mounting Requirements

Mount the inverter vertically or tilted backward by max 15°. In order to facilitate the heat dissipation of the inverter.

<b>NOTICE</b>	A wrong installation mode would cause the inverter to be damaged or unable to work properly.
---------------	--

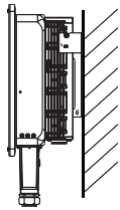

Upright

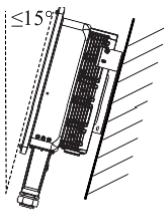

Lean back  $\leq 15^\circ$

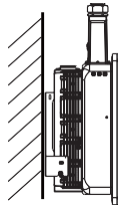

Upside-down

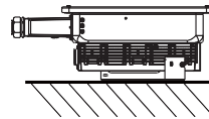

Horizontally

### 4.1.3 Requirements for Installation Space

To keep the inverter normal and easy to operate, the requirements for available spaces of the inverter must be followed, e.g. to keep enough clearance. For details, see the following figures.

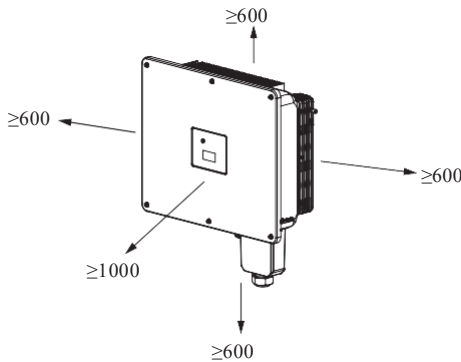

Above: 600

Below: 600

Front: 1000

Both sides: 600

Unit: mm

Installation along the same line for multiple inverters:

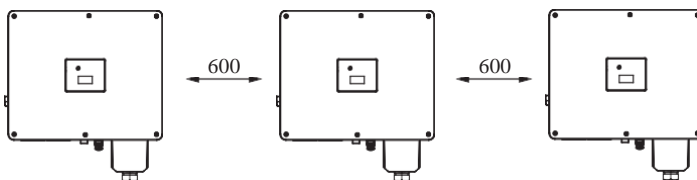

Unit: mm

Installation perspective schematic:

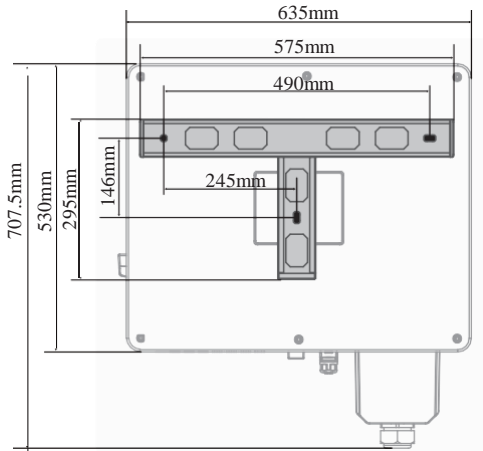

## 4.2 Mounting

### 4.2.1 Install the Mounting Bracket

#### 4.2.1.1 Wall-Mounted Installation



**DANGER**

1. The walls must be fireproof and non-flammable materials, otherwise there is a fire risk.
2. Before drilling holes, check whether there are electric power pipes buried in the walls to avoid risks.

- Step1 Use a level ruler to mark the positions for drilling holes on the installation site..

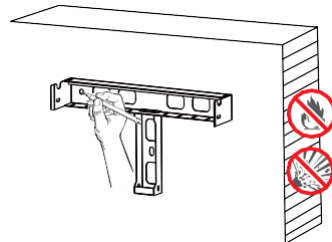

- Step2 Drill 3 holes, 16mm in diameter and 55 mm in depth.

Φ16 mm  
Depth: 55mm



## Installation

- Step3 Insert the expansion bolts into the holes and secure them with a hammer.

Then remove the nut, spring washer, and flat washer.

Note: Do not remove the nut before performing this step.

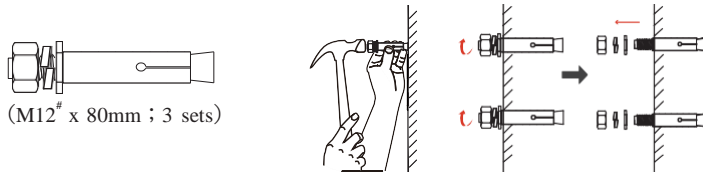

(M12<sup>#</sup> x 80mm ; 3 sets)

- Step4 Fix the mounting-bracket with the expansion bolts. Screw: 3\*M12, torque: 26N·m.

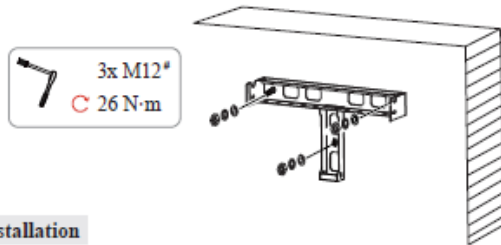

### 4.2.1.2 (Optional) Bracket-Mounted Installation

- Step1 Mark the positions for drilling holes on the installation site.

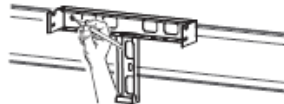

- Step2 Drill 3 holes, 14mm in diameter.



- Step3 Tighten the support and the rear panel with 3 sets of M12 screw kit.

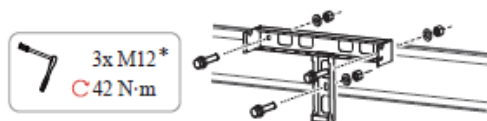

**NOTE:** M12<sup>\*</sup>: screws for bracket mounting.  
M12<sup>#</sup>: expansion screws for wall mounting.



### 4.2.2 Install the Inverter

Hook the inverter into the bracket accurately and tighten the screws at both sides.

We recommend at least two persons to carry the inverter.

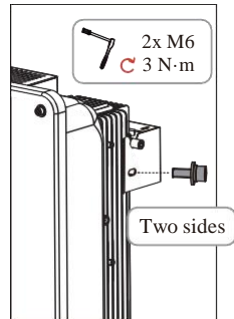
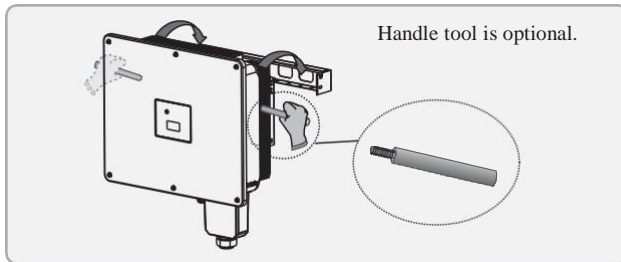
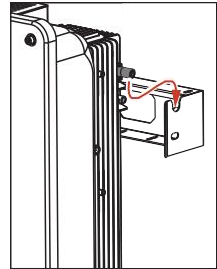
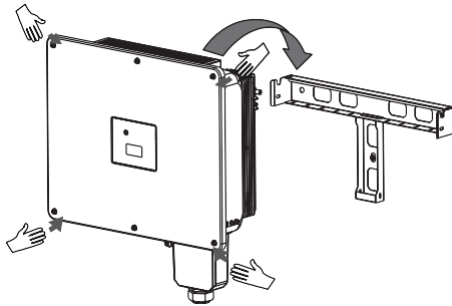

**CAUTION**

To prevent damage of the inverter, please hang the inverter on the bracket and confirm the reverse, do not loosen the handle until the inverter is fixed.

## 5 Electrical Connection

### System Connection

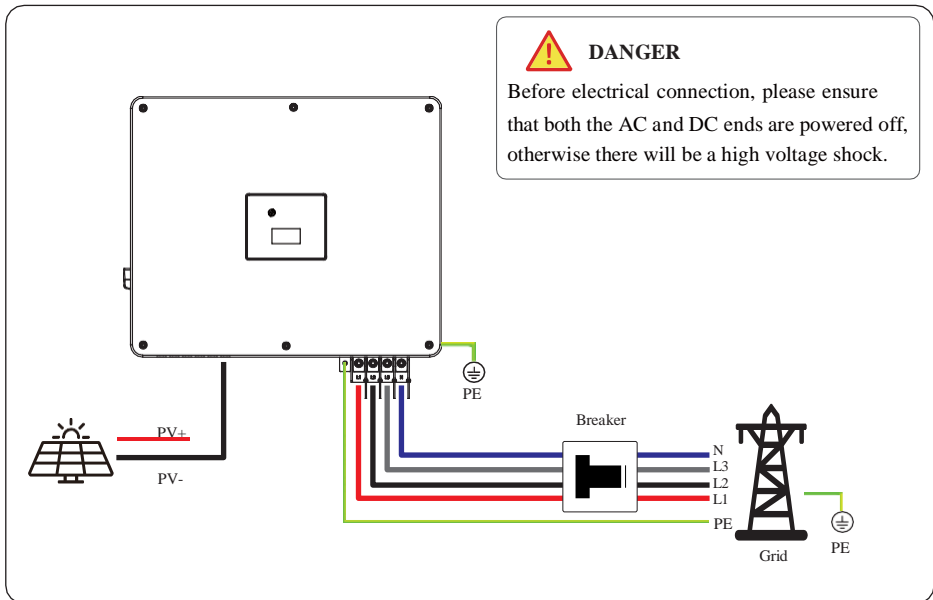

**NOTE:**

The cable colors in figures are only for reference. Select appropriate cables according to the local standards.

## 5.1 Grounding

According to the EN50178 requirement, the right side of the device has a protective grounding connection. Be sure to connect the protection ground cable to this port when installing the inverter. Users should perform the ground connection according to the on-site condition.

- Step1 Remove an appropriate length using a wire Stripper.

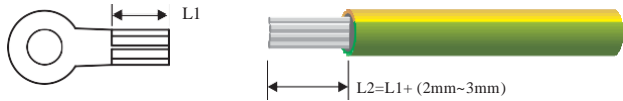

- Step2 Insert the exposed core wires into the crimping areas of the OT terminal and crimp them using hydraulic pliers.

Recommended OT Terminal: OT16~25-6

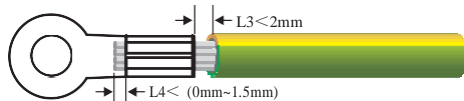

- Step3 Remove the ground screws from the ground points.

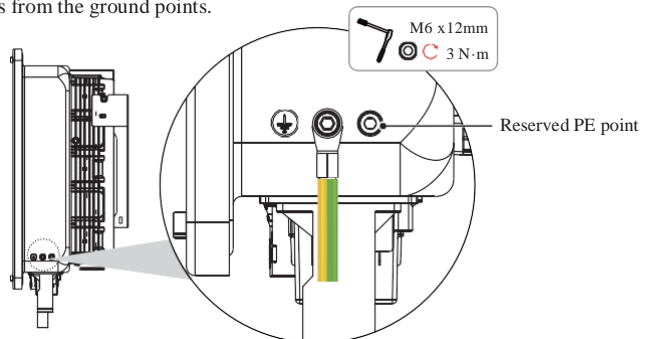

### WARNING

According to regulations, the secondary protection grounding can't replace the PE terminal connection of the AC cable. Ensure that both are grounded reliably; otherwise, fatal injury can occur due to the high voltage.



### CAUTION

If the positive pole or negative pole of the PV array is required to be grounded, then the inverter output (to AC grid) must be isolated by transformer in accordance with IEC63109-1,-2 standards.

## 5.2 AC Connection

### 5.2.1 AC cable connection

1. Measure and access the voltage and frequency of the point to ensure that it meets the grid-tied specifications of the inverter.
2. PE wire (GND) must be well grounded to ensure that impedance between Neutral wire and Earth wire is less than  $10\Omega$ .
3. Disconnect the circuit breaker or fuse from the inverter and grid-connected access point.
4. Use the copper wire.
5. Follow the steps below.

- Step1 Select proper AC cables and OT terminals (5 wires), and strip cables.

Note:It is recommended to use outdoor dedicate cables with multiple copper cores.

100 mm(recommended)

A

B

Model	A	B
30K	25...31 mm	16...35 mm <sup>2</sup>
40K/LV25K	32...38 mm	25...50 mm <sup>2</sup>
50/60K LV30/36K	32...38 mm	35...50 mm <sup>2</sup>

M8

L1

L1 + 2 mm

Recommended OT Terminal:

- 30K: OT16~35-8
- 40K/LV25K: OT25~50-8
- 50/60K/LV30/36K: OT35~50-8

- Step2 Wires threading and pressing.

- Insert AC separators
- loosen the cable gland and thread the AC cable (5 wires) cross the gland, threaded sleeve and the AC cover. Then crimp the OT terminal and use heat shrink tubing or insulation tape for protection.

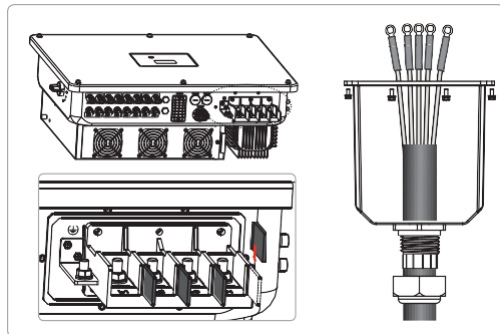

- Step3 Lock the AC cable to corresponding AC terminals. Screw: 5\*M8, torque:10 N·m

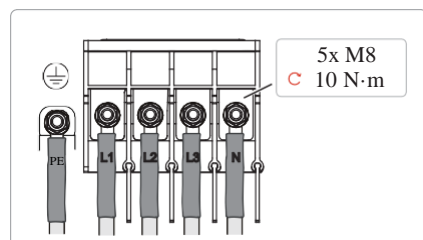

- Step4 Install AC cable cover.
  - Align the AC cover with the 6 holes and tighten it firmly with 6×M4 screws. Torque: 1.2 N·m
  - Fasten the nut (waterproof cap). Torque: 12 N·m

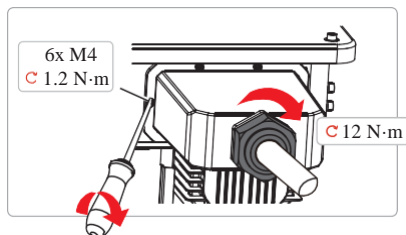

## 5.2.2 AC Breaker and Leakage current protector

To ensure that the inverter is safely disconnected from the grid, the independent AC breaker must be configured for each inverter as a protective device.

<b>WARNING</b>	<ul style="list-style-type: none"> <li>▪ Multiple inverters are not allowed to share a circuit breaker.</li> <li>▪ Load is not allowed to connect between the inverter and the AC breaker.</li> </ul>
----------------	---

Inverter Model	Recommended Value
SE-TH02 30.0TL3	63A
SE-TH01 40.0TL3	100A
SE-TH01 50.0TL3, SE-TH01 60.0TL3	125A

Internal current detection equipment for inverter, the inverter detects the leakage of the power grid that is greater than the reduced value, and will be disconnected quickly from the power grid. If the external installation leakage protection device is installed, its action electricity must be greater than equal to 300mA.

## 5.3 PV Connection

 <b>DANGER</b>	<ul style="list-style-type: none"> <li>▪ PV modules generate electric energy when exposed to sunlight and can create an electrical shock hazard. Therefore, when connecting the PV modules, shield them with opaque cloth and ensure that DC switches are OFF. To avoid electric shock, don't touch the charge part and connect the terminals carefully.</li> <li>▪ Before connecting power cables, ensure the AC/DC switches are OFF.</li> <li>▪ When the inverter is connected to the grid, don't plug in or plug out the PV strings.</li> <li>▪ Don't perform any operation until the inverter is shut down.</li> </ul>
---	--

 <b>WARNING</b>	<ul style="list-style-type: none"> <li>▪ PV modules connected in series in each PV string must be of the same specifications.</li> <li>▪ The maximum open-circuit voltage of each PV string must be always lower than or equal to its permitted range.</li> <li>▪ The maximum short circuit current of each PV string must be always lower than or equal to its permitted range.</li> <li>▪ Ensure that the positive and negative terminals of each PV strings connected to the inverter correctly.</li> <li>▪ The positive or negative terminals of PV strings can't be connected with short circuit.</li> <li>▪ The total output power of all PV strings can't exceed the maximum input power of the inverter.</li> </ul>
--	---

 <b>NOTICE</b>	<ul style="list-style-type: none"> <li>▪ The positive and negative terminals of PV modules can't connect to PE wire (GND), otherwise, the inverter will be damaged.</li> <li>▪ Ensure that the voltage of each PV string doesn't exceed 1100V under any circumstances.</li> <li>▪ When the input voltage is 1000V to 1100V, the inverter will enter the standby state. When the voltage returns to the MPPT operating voltage, namely 180V-1000V, the inverter will return to the normal state.</li> </ul>
---	--

### 5.3.1 Preparation

The configuration table for different numbers of PV input strings is shown as below.

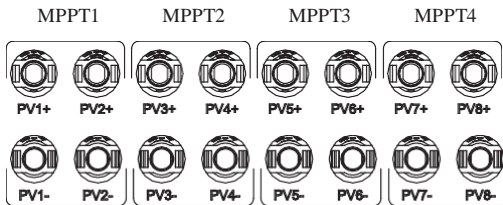

Model	Number of PV strings	MPP-Tracker			
		1	2	3	4
30/40K/ (LV25K)	1	PV1			
	2	PV1	PV3		
	3	PV1	PV3	PV5	
	4	PV1, 2	PV3	PV5	
	5	PV1, 2	PV3, 4	PV5	
	6	PV1, 2	PV3, 4	PV5, 6	
50/60K/ (LV30/36K)	1	PV1			
	2	PV1	PV3		
	3	PV1	PV3	PV5	
	4	PV1	PV3	PV5	PV7
	5	PV1, 2	PV3	PV5	PV7
	6	PV1, 2	PV3, 4	PV5	PV7
	7	PV1, 2	PV3, 4	PV5, 6	PV7
	8	PV1, 2	PV3, 4	PV5, 6	PV7, 8

Before connecting the PV input to the inverter, ensure that the package meets the following electrical specifications.

Inverter module	Limit of each input open-circuit voltage	Maximum allowable input terminal current
All	1100V	25A

Open-circuit voltage altitude derating curve of the inverter as shown in the following figure

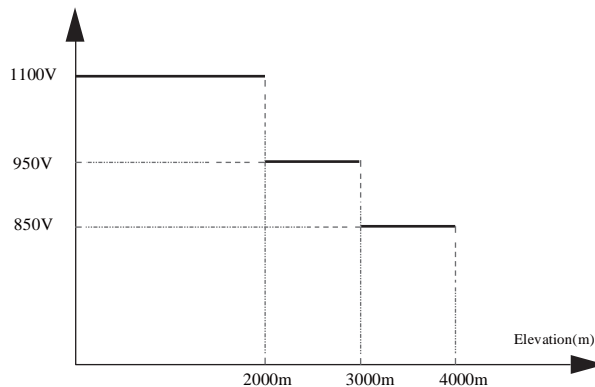

#### NOTE

To ensure that the inverter reaches the enclosure of IP66, it can only use the connector provided by supply.

### 5.3.2 PV Connection

PV connection please refer to below figures.

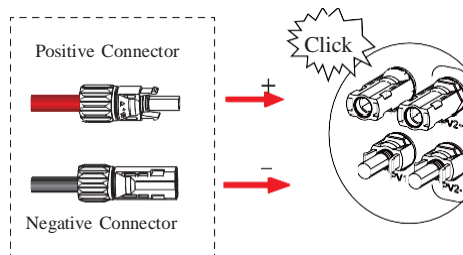
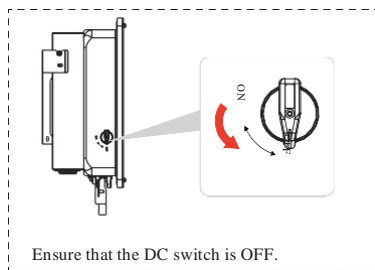
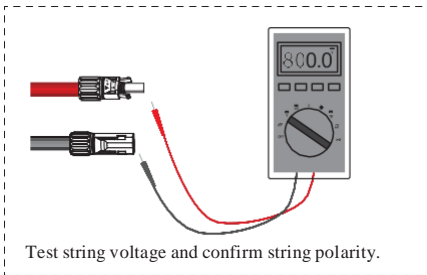
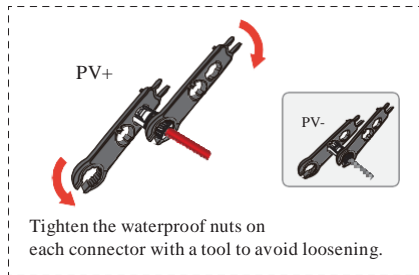
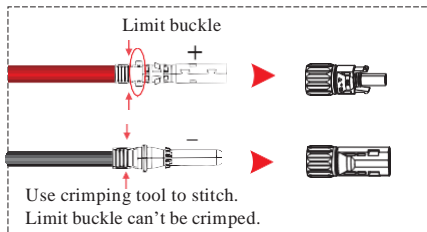
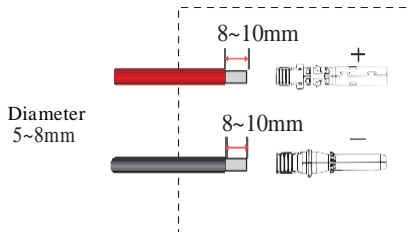
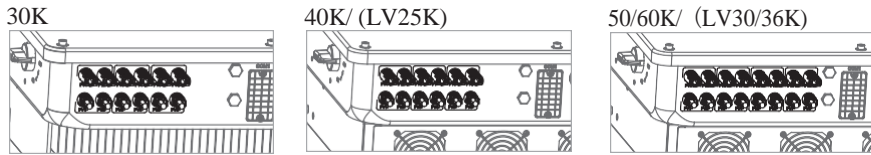

<p><b>DANGER</b></p>	<ol style="list-style-type: none"> <li>1. Photovoltaic arrays exposed to sunlight will generate dangerous voltages!</li> <li>2. Before connecting the DC terminal, ensure that both the AC terminal and the DC terminal are powered off and the DC switch is OFF. Otherwise there is a risk of high voltage shock.</li> <li>3. Please check polarity of PV connectors! If polarity reversed, do not try to disconnect any PV connector until the irradiance declines and the DC currents fall below 0.5 A! Only then disconnect the PV plugs and correct the polarity before reconnecting.</li> </ol>
----------------------	---



## 5.4 Communication Connection

### 5.4.1 Communication Mode Description

You can use the following communication modes to implement communication:

Bluetooth, WIFI, 4G and RS485, all of which are described as follows.

- **Bluetooth Module**  
You can turn on the Bluetooth function of the mobile phone, and set parameters and monitor data of the inverter through the mobile APP.
- **WIFI/4G Modules**  
Through DB9 communication interface, the communication signal is transferred to other communication modules to monitor the inverter.
- **RS485 Module**  
Through a 12-Pin terminal, the inverter can connect to a data logger to achieve data exchange with cloud devices.

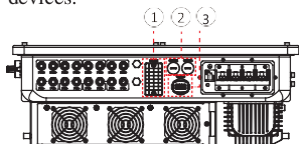

Fan cooling series

(Only take the 50K as an example in appearance)

Number	Description
①	COM1 (for WIFI module communication)
②	COM2/3 (reserved communication ports)
③	COM4 (for RS485 communication)

### 5.4.2 WIFI Module Installation

For details, please refer to the corresponding Module Installation Guide in the pack. The appearance of the actual modules may be slightly different. The figures shown here are only for illustration.

- **Step1** Loosen two screws and remove the cover.

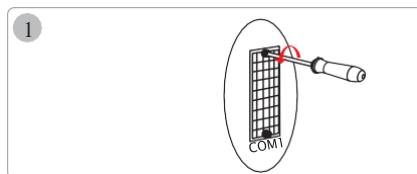

- **Step2** Insert WIFI module into COM1 port, and ensure it will not fall off.

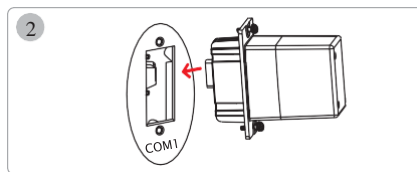

- **Step3** Install/secure the module.

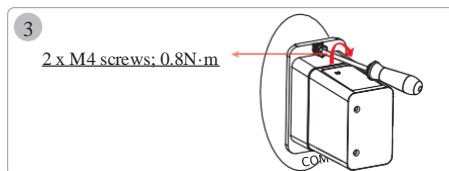

### 5.4.3 RS485 Installation

#### RS485 Terminal Overview

Front:



Rear:



Note:

Please connect the RS485 signal cables at the rear side of this terminal.

The multiple inverters network and RS485 communication is as follows:

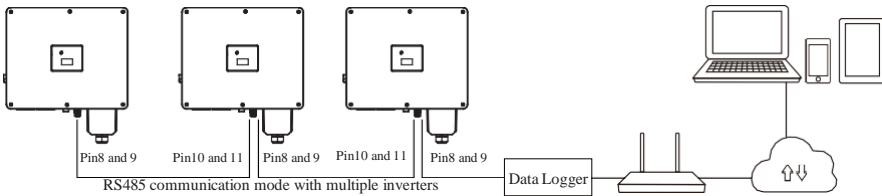

#### RS485 Installation Steps:

- Step1 Strip an RS485 communication cable.

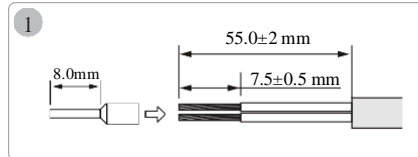

- Step2 Pull out the terminal's inner part ( a 12-pin connector).

The diagram shows the rear side of the terminal with a 12-pin connector. A red arrow points to the 'rear side' of the terminal. The connector has 12 pins labeled 1 through 12.

Pin	Inverter	Pin	Inverter
6	DI1O	12	PE
5	ALM	11	A
4	EXT_SIG	10	B
3	DI2	9	A
2	DI1	8	B
1	GNDS	7	PE

- Step3 Unscrew the waterproof nut at the end of the terminal. Remove sealing plugs and thread wires.

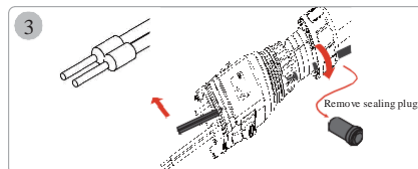

- Step4 Install signal cables into the 12-pin connector according to the definition table in step2.

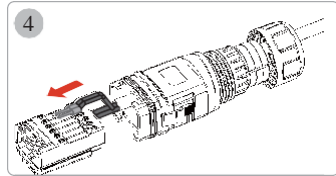

- Step5 Tighten signal cables with a screwdriver.

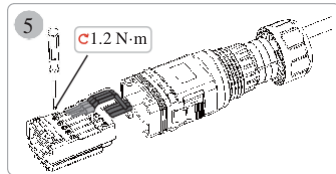

- Step6 Insert the 12-pin connector back to its terminal enclosure.

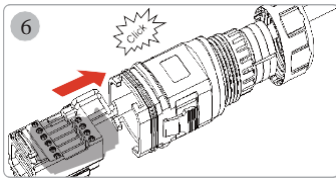

- Step7 Insert sealing plugs back and tighten the waterproof nut.
- Step8 The RS485 terminal is well-prepared.

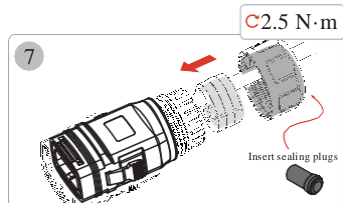
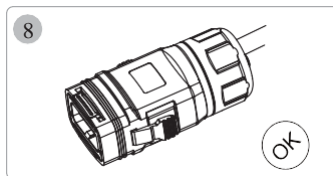

- Step9 Insert the assembled RS485 terminal into COM4 port of the inverter.

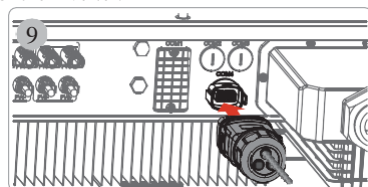

### 5.4.4 Modbus Address setting

① Download the APP.

- Scan the QR code on the inverter to download the APP.
- Download the APP from the App Store or Google Play.

Note: the APP should access some permissions such as inverter's location. You need to grant all rights in all pop-up windows when installing the APP or setting your phone.

② Power on the inverter.

③ Connect the Inverter.

Open the Bluetooth on your own phone, then open the APP. Then follow the instructions below.

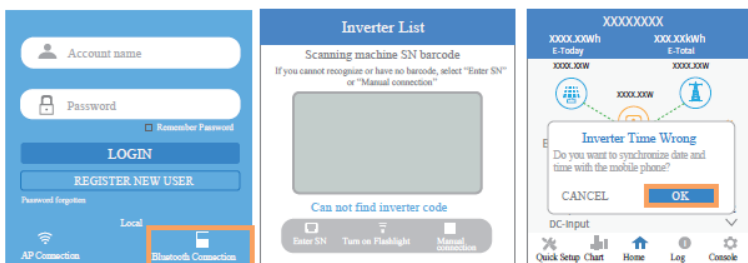

④ Go to Console > Communication Setting > RS485 Setting > Modbus Page, check the Modbus address (the default value is 1), and click to modify the address as required if necessary.

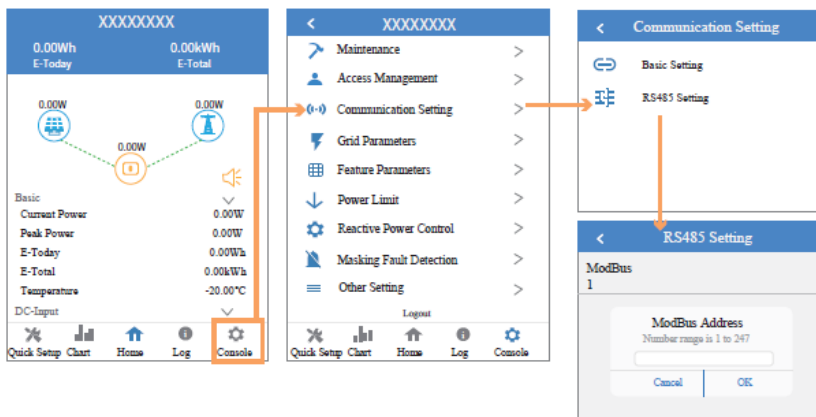

## 6 Startup/Shutdown Procedure

### 6.1 Check before Startup/Shutdown Procedure

Check following this steps after installation.

No.	Items
1	The inverter is firmly installed.
2	There is enough heat dissipation space, no external objects or parts left on the inverter.
3	It is convenient for operation and maintenance.
4	The wiring of the system is correct and firm.
5	Check whether the DC and AC connections are correct with a multimeter, and ensure there is no short circuit, break, or wrong connection.
6	Check whether the waterproof nuts of each part are tightened.
7	The vacant ports have been sealed; all gaps at the cable inlet and outlet holes have been plugged with fireproof/waterproof materials, such as fireproof mud.
8	All safety labels and warning labels on the inverter are complete and without occlusion or alteration.

### 6.2 Startup Procedure

Startup procedure following the procedures :

#### Supply Main Switch

See if there's any on site  
(The figure is only for reference)

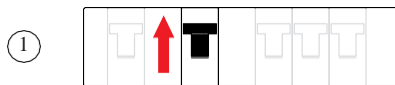

#### AC Circuit Breaker

Switch to ON  
(The figure is only for reference)

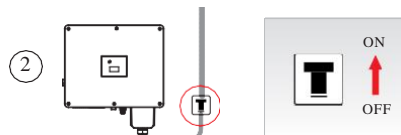

#### PV Switch

Switch to ON

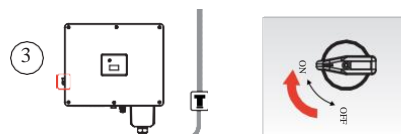

#### LED icon

Blue on (normal status)

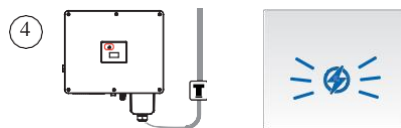

#### Sync Time

⑤ Go to APP > Scan SN barcode on the inverter > Synchronize inverter time with mobile phone

#### Finishing

⑥ Your system has been started up

## 6.3 Shutdown Procedure

It may be necessary to shut down the inverter sometimes during the daily use. If necessary, please follow the procedures:

### Supply Main Switch

See if there's any on site  
(The figure is only for reference)

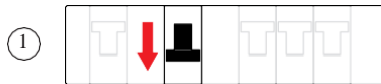

### AC Circuit Breaker

Switch to OFF  
(The figure is only for reference)

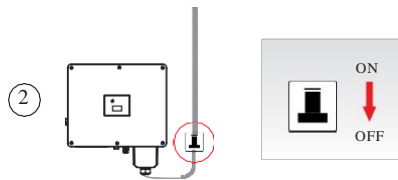

### PV Switch

Switch to OFF

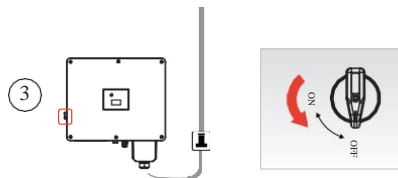

### Wait at least 30 minutes

Let inverter discharge to  
a safe voltage range (<35V).



### Finishing

⑤ Your system has been shutdown



### WARNING

After the inverter is powered off, the heat sink generates heat and there is excess electricity in the inverter. To avoid electric shocks and burns, powered off inverter for at least 30 minutes before performing operations.

## 7 User Interface

Inverter display panel is consisted of LED indicator and LCD.

Please find the LED status and its corresponding explanations in Table 7-1; the details of LCD screen in Figure 7-2; and warning information in Table 7-3.

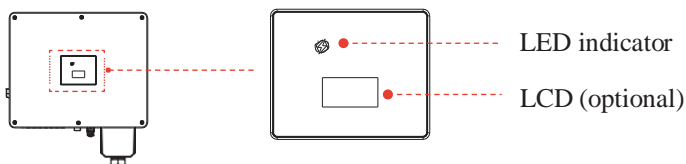

### 7.1 LED

Table 7-1 LED Status Description

LED status	Descriptions
Blue led blink slowly 1s/time	Standby or startup state (not connected to the grid)
Blue on	Grid-tied status
Green on	Power limited status
Red led blink slowly 1s/time	Output side fault
Red led blink quickly 0.25s/time	Input side fault
Red led on	System internal fault
Red/Green/Blue light up alternately (1 color /0.25s)	Burning code(Master/Slave)
	Control power set up (last for 1s)
	LED self-check mode

## 7.2 LCD

Figure 7-2 LCD Screen

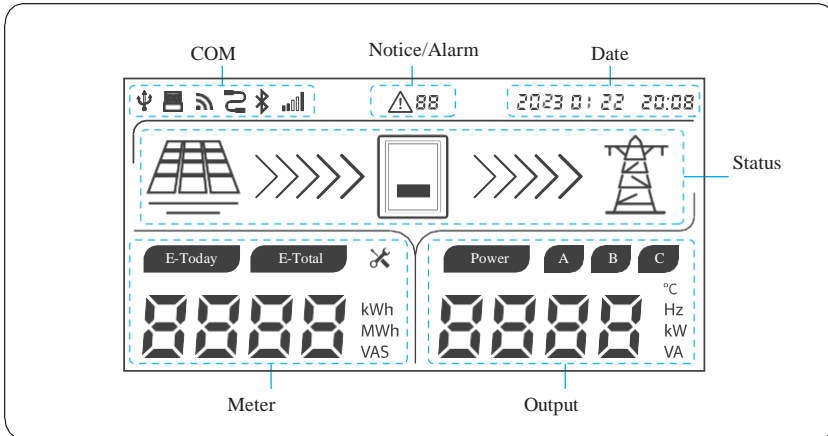

### COM

When WIFI/Bluetooth is transferring data, icon will be ON, while no data transmission, the icon will be off after 10s. When RS485 is transferring data, icon will be ON, while no data transmission, the icon will be off after 10s.

### Warning

When warning is triggered, icon will be illuminated: from left to right the first bit could be A/ B/ C, it stands for warning type, and the second bit is warning code, please refer to warning code in table for details.

### Date

When external communications is normal and time zone is set correctly, the built-in clock of inverter will be synchronized with server's time. Without external communications, it is recommended to use the mobile app to set up time through connecting Bluetooth to the inverter.

### Status

Icon stands for PV strings, when inverter is in standby status, MPPT voltage of the PV string will be displayed in Meter zone.

Icon stands for grid, when voltage and frequency of power grid is in normal range, the icon keeps on, or else, it blinks; when there is no voltage, the icon will be off.

Icon stands for energy flow, when inverter is in normal status, the icon will be on, or else it will be off.



## Meter



Normal status: today and total energy, MPPT voltage and current are showed in turn.	
Standby status: counter down value before inverter start up.	
Any status: setting parameters via APP, the screen keeps for 5 seconds.	
Normal status: output power, grid voltage and current are showed in turn.	

Table 7-2 Warning Table

Status	Details	Warning code
Red blink slowly (1s/time)	Grid over voltage	A0
	Grid under voltage	A1
	Grid absent	A2
	Grid over frequency	A3
	Grid under frequency	A4
	Grid abnormal	A6
	Grid high average voltage	A7
	Grid N abnormal	A8
Red blink quickly (0.25s/time)	PV over voltage	B0
	PV Insulation resistance abnormal	B1
	Leakage current abnormal	B2
	PV Strings reverse	B7
Red on	PV under voltage	B4
	Control power abnormal	C0
	Arc fault	C1
	High DC component of output current	C2
	Inverter relay abnormal	C3
	Inverter over temperature	C5
	Leakage current HCT abnormal	C6
Red on	System type error	C7
	DC link voltage unbalanced	C9
	DC link over voltage	CA
	Internal communication error	CB
	Software incompatibility	CC
	EEPROM error	CD
	Consistent warning	CE
	Inverter abnormal	CF
	Boost abnormal	CG
	Master Lost	CH
Meter lost	CJ	
/	Fan abnormal	C8
	Remote off	CN

Note: If you choose the LCD screen, the warning code will be displayed on the screen. Non-led screen models need to enter the app to view corresponding warning code.

## 8 Troubleshooting and Maintenance

 <b>WARNING</b>	<p>Before maintaining and commissioning inverter and its peripheral distribution unit, switch off all the charged terminals of the inverter and wait at least 10 minutes after the inverter is powered off, otherwise there will be a high voltage shock..</p>
 <b>DANGER</b>	<ul style="list-style-type: none"> <li>▪ Wrong maintenance will result in personnel injury or equipment damage!</li> <li>▪ Before performing any maintenance operations, you must follow these steps: First, disconnect the AC circuit breaker on the grid side, and then disconnect the DC switch. Wait at least 10 minutes after the inverter is powered off, otherwise there will be a high voltage shock.</li> <li>▪ Use testing equipment to make sure there no voltage or current.</li> </ul>
 <b>NOTICE</b>	<ul style="list-style-type: none"> <li>▪ Comply with ESD protection specifications and power distribution ESD bracelets.</li> <li>▪ Avoid unnecessary contact with the circuit board.</li> <li>▪ Touching printed circuit boards or other electrostatic sensitive components may cause damage during the process.</li> </ul>

### 8.1 Troubleshooting

If the inverter is broken down, the LED indicators will turn to red.

Alarm Information	Measures Recommended
A0-Grid over voltage	<ol style="list-style-type: none"> <li>1. If the alarm occurs accidentally, possibly the power grid is abnormal accidentally. No extra action is needed.</li> <li>2. If the alarm occurs repeatedly, contact the local power station. After receiving approval of the local power bureau, revise the electrical protection parameter settings on the inverter through APP.</li> <li>3. If the alarm persists for a long time, please confirm that:               <ol style="list-style-type: none"> <li>1) The AC circuit breaker is not tripping frequently (generating an instantaneous high voltage);</li> <li>2) The wiring of AC cable is followed by the guide in user manual, and high cable impedance can cause a voltage rise on the grid;</li> <li>3) The voltage of three-phase inverter between the neutral wire and the ground line exceeds 30V; and please correct the grid wiring if it exceeds;</li> </ol> </li> </ol> <p>If the above problems are excluded, please contact customer service to report a repair.</p>
A1-Grid under voltage	<ol style="list-style-type: none"> <li>1. If the alarm occurs accidentally, possibly the power grid is abnormal temporarily. No extra action is needed.</li> <li>2. If the alarm occurs repeatedly, contact the local power station. After receiving approval of the local power bureau, revise the electrical protection parameter settings on the inverter through APP.</li> <li>3. If the alarm persists for a long time, please confirm that:               <ol style="list-style-type: none"> <li>1) The AC circuit breaker is disconnected;</li> <li>2) The AC circuit breaker is damaged (under closed status, please check that the voltage of the inlet is inconsistent with that of the outlet);</li> <li>3) The AC terminals are in good contact.</li> </ol> </li> </ol> <p>If the actual measuring voltage is within the specified range, please contact customer service to report a repair.</p>

A2-Grid absent	<ol style="list-style-type: none"> <li>1. If the alarm occurs accidentally, possibly the power grid is abnormal temporarily. No extra action is needed.</li> <li>2. If the alarm occurs repeatedly, contact the local power station. After receiving approval of the local power bureau, revise the electrical protection parameter settings on the inverter through APP.</li> <li>3. If the alarm persists for a long time, please confirm:                     <ol style="list-style-type: none"> <li>1) The AC circuit breaker is disconnected;</li> <li>2) The AC circuit breaker is damaged (under closed status, please check that the voltage of the inlet is consistent with that of the outlet);</li> <li>3) The AC terminals are in good contact;</li> <li>4) Whether the power supply line failure.</li> </ol> </li> </ol> If exclude all possibilities, please contact customer service to report a repair.
A3-Grid over frequency	<ol style="list-style-type: none"> <li>1. If the alarm occurs accidentally, possibly the power grid is abnormal temporarily. No extra action is needed.</li> <li>2. If the alarm occurs repeatedly, contact the local power station. After receiving approval of the local power bureau, revise the electrical protection parameter settings on the inverter through APP.</li> </ol>
A4-Grid under frequency	<ol style="list-style-type: none"> <li>1. If the alarm occurs accidentally, possibly the power grid is abnormal temporarily. No extra action is needed.</li> <li>2. If the alarm occurs repeatedly, contact the local power station. After receiving approval of the local power bureau, revise the electrical protection parameter settings on the inverter through APP.</li> <li>3. If the alarm persists for a long time, please contact the customer service.</li> </ol>
A6-Grid abnormal (Only for three-phase inverter)	<ol style="list-style-type: none"> <li>1. If the alarm occurs accidentally, possibly the power grid is abnormal temporarily. No extra action is needed.</li> <li>2. If the alarm occurs repeatedly, please:                     <ol style="list-style-type: none"> <li>1) Measuring three-phase voltages (L1-N, L2-N, L3-N) and check whether the imbalance is more than 30%. If yes, please contact energy company.</li> <li>2) Measuring three-phase voltages at input and output sides of AC circuit breaker to check whether breaker is damaged. If yes, please replace a new breaker.</li> <li>3) Short circuit input and output ports of neutral wire on AC breaker, then check the alarm status. If it returns normal, please replace a 3-pole breaker and keep neutral wire shorting. If not, please contact customer service.</li> </ol> </li> </ol>
A7-Grid over mean voltage	<ol style="list-style-type: none"> <li>1. If the alarm occurs occasionally, the inverter can be automatically recovered. No extra action is needed.</li> <li>2. If the alarm occurs repeatedly, the inverter cannot work properly. Please contact customer service.</li> </ol>
A8-Grid N abnormal	<ol style="list-style-type: none"> <li>1. If the alarm occurs occasionally, the inverter can be automatically recovered. No extra action is needed.</li> <li>2. If the alarm occurs repeatedly, the inverter cannot work properly. Please contact the customer service center.</li> </ol>
B0-PV over voltage	Check whether the maximum input voltage of a single PV string exceeds the MPPT working voltage. If yes, modify the number of PV module connection strings.
B1-PV insulation abnormal	<ol style="list-style-type: none"> <li>1. If the alarm occurs accidentally but the inverter can generate power, check whether the installation environment of cables and the components are damp. Please improve the installation environment.</li> <li>2. If the alarm occurs repeatedly and the inverter can generate electricity occasionally, check whether the positive and negative polarity of the PV component are short-circuited to ground. And check if the component is damaged or the connection cable is broken.</li> <li>3. If the alarm continues and equipment cannot generate power, please contact customer service to report a repair.</li> </ol>
B2-Leakage current abnormal	<ol style="list-style-type: none"> <li>1. If the alarm occurs accidentally but the inverter can generate power, probably the power grid causes. inverter can be automatically recovered. No extra action is needed.</li> <li>2. If the alarm occurs frequently and is accompanied by an insulation impedance alarm. Check for the abnormal alarm of the insulation.</li> <li>3. If the alarm continues and the equipment cannot generate electricity, please contact customer reserve to export a repair.</li> </ol>
B4-PV under voltage	<ol style="list-style-type: none"> <li>1. If occurs when the light is weak (such as the early morning or evening, rainy weather and dust storms), the component voltage is lower than normal. No extra action is needed.</li> <li>2. If not related to light intensity, please check whether the string has a short circuit or open circuit.</li> </ol>
B7-PV string reverse	Check and modify the positive and negative polarity of the input string.

C0-Internal power supply abnormal	<ol style="list-style-type: none"> <li>1. If the alarm occurs occasionally, the inverter can be automatically recovered. No extra action is needed.</li> <li>2. If the alarm occurs repeatedly. Please contact customer service.</li> </ol>
C1-Electric arc abnormal	If the alarm occurs, the inverter cannot work properly. Please contact customer service.
C2-Inverter over dc-bias current	<ol style="list-style-type: none"> <li>1. If the alarm occurs occasionally, the inverter can be automatically recovered. No action is required.</li> <li>2. If the alarm occurs repeatedly, the inverter cannot work properly. Please contact customer service.</li> </ol>
C3-Inverter relay abnormal	<ol style="list-style-type: none"> <li>1. If the alarm occurs occasionally, the inverter can be automatically recovered. No action is required.</li> <li>2. If the alarm occurs repeatedly, for single-phase inverter, check whether the live line and neutral line on the AC side is reversed. For three-phase inverter, check the voltage of the live line and neutral line to the ground. If the grid side is normal, please contact customer service to report a repair.</li> </ol>
C5-Inverter over temperature	<ol style="list-style-type: none"> <li>1. If the alarm occurs occasionally, the inverter can be automatically recovered. No action is required.</li> <li>2. If the alarm occurs repeatedly, please check whether the installation site has direct sunlight, bad ventilation, or high ambient temperature (such as installed on the parapet). Yet, if the ambient temperature is lower than 45° C and the heat dissipation and ventilation is good, please contact customer service.</li> </ol>
C6-GFCI abnormal	<ol style="list-style-type: none"> <li>1. If the alarm occurs occasionally, it could have been an occasional exception to the external wiring. The inverter can be automatically recovered. No action is required.</li> <li>2. If it occurs repeatedly or cannot be recovered for a long time, please contact customer service.</li> </ol>
C7-System type error	If the alarm occurs, and the inverter cannot work, please restart the inverter. If the alarm continues, please contact customer service.
C9-Unbalance Dc-link voltage	<ol style="list-style-type: none"> <li>1. If the alarm occurs occasionally, the inverter can be automatically recovered. No action is required.</li> <li>2. If the alarm occurs repeatedly, the inverter cannot work properly. Please contact customer service.</li> </ol>
CA-Dc-link over voltage	<ol style="list-style-type: none"> <li>1. If the alarm occurs occasionally, the inverter can be automatically recovered. No action is required.</li> <li>2. If the alarm occurs repeatedly, the inverter cannot work properly. Please contact customer service.</li> </ol>
CB-Internal communication error	<ol style="list-style-type: none"> <li>1. If the alarm occurs occasionally, the inverter can be automatically recovered. No action is required.</li> <li>2. If the alarm occurs repeatedly, the inverter cannot work properly. Please contact customer service.</li> </ol>
CC-Software incompatibility	<ol style="list-style-type: none"> <li>1. If the alarm occurs occasionally, the inverter can be automatically recovered. No action is required.</li> <li>2. If the alarm occurs repeatedly, the inverter cannot work properly. Please contact customer service.</li> </ol>
CD-Internal storage error	<ol style="list-style-type: none"> <li>1. If the alarm occurs occasionally, the inverter can be automatically recovered. No action is required.</li> <li>2. If the alarm occurs repeatedly, the inverter cannot work properly. Please contact customer service.</li> </ol>
CE-Data inconsistency	<ol style="list-style-type: none"> <li>1. If the alarm occurs occasionally, the inverter can be automatically recovered. No action is required.</li> <li>2. If the alarm occurs repeatedly, the inverter cannot work properly. Please contact customer service.</li> </ol>

CF-Inverter abnormal	1. If the alarm occurs occasionally, the inverter can be automatically recovered. No action is required. 2. If the alarm occurs repeatedly, the inverter cannot work properly. Please contact customer service.
CG-Boost abnormal	1. If the alarm occurs occasionally, the inverter can be automatically recovered. No action is required. 2. If the alarm occurs repeatedly, the inverter cannot work properly. Please contact customer service.
CH-Data logger lost	1. If the alarm occurs occasionally, the inverter can be automatically recovered. No action is required. 2. If the alarm occurs repeatedly, the inverter cannot work properly. Please contact customer service.
CJ-Meter lost	If the alarm occurs, please check the RS485 connection. If it is abnormal, please revise the connection; if it is normal, please contact customer service.
C8-Fan abnormal	1. If the alarm occurs occasionally, please restart the inverter. 2. If it occurs repeatedly or cannot be recovered for a long time, check whether the external fan is blocked by other objects. Otherwise, please contact customer service.

## 8.2 Maintenance

### Routine Maintenance of inverter

Check Item	Check Content	Maintain content	Maintenance Interval
Inverter output status	Statistically maintain the status of electrical yield, and remotely monitor its abnormal status.	NA	Weekly
Inverter appearance	Check periodically and ensure that the heat sink is free from dust and blockage.	Clean periodically the heat sink.	Yearly
Inverter running status	a.Check that the inverter is not damaged or deformed. b.Check for normal sound emitted during inverter operation. c.Check and ensure that all inverter communications are running well.	If there is any abnormal phenomenon, replace the relevant parts.	Monthly
Inverter Electrical Connections	a.Check and ensure that AC, DC, and communication cables are securely connected; b.Check and ensure that PGND cables are securely connected; c.Check and ensure that cables are intact and free from aging;	If there is any abnormal phenomenon, replace the cable or re-connect it.	Semiannually

Table 8-1. Maintenance checklist and interval

### Fan Maintenance

When the external fan of the inverter can't work normally, the inverter may not cool effectively. It may affect the efficiency of the inverter or cause derating operation. Keep the fan clean and replace the damaged fan in time.

Step1 Do the shutdown procedure.

Step2 Refer to electrical connection installation and disconnect the inverter in the opposite steps.

Step3 Refer to mechanical installation and remove the inverter in the opposite steps.

Step4 Screw down the security screw anticlockwise which on the inverter fan bracket.

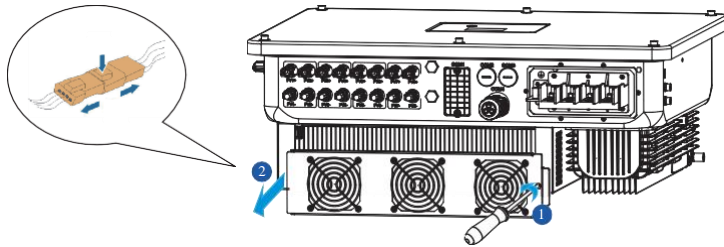

(Only take 50K model as an example)

Step5 Use a soft brush to clean the fan. If you need to replace the fan, use a screwdriver to unscrew the fan bracket and remove the fan.

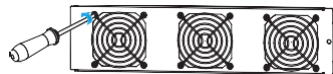

Step6 Install the new fan in the opposite steps, and then power on the system.

.....End

### Inverter Uninstall

Inverter uninstall requires below procedure:

Step1 Disconnection all electric connections including these of communications cables, DC input cables, AC output cables and the PGND cables.

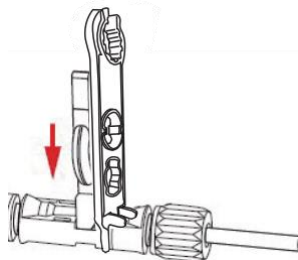

Figure 8.1 Removing DC input connector

Note:

When uninstalling DC input connectors, insert removal wrench into the bayonet shown in Figure, press the wrench down, and take out the connector.

Step2 Remove the inverter from its rear panel.

Step3 Remove the rear panel.

.....End

<b>WARNING</b>	<p>Before uninstalling all electric connections, DC input connector, AC output cables and the PGND cables, please ensure that both the AC terminal and the DC terminal are powered off. And the DC switch is OFF to avert equipment damage or personal injury.</p>
----------------	--

## 9 Technical Specifications

Model SE-TH01	30.0TL3	40.0TL3	50.0TL3	60.0TL3
<b>Efficiency</b>				
Max Efficiency		98.5%		98.6%
European Efficiency	98.0%		97.9%	98.0%
<b>Input (PV)</b>				
Max. Input Voltage		1,100V		
Max. PV Configuration (STC)		150%		
Rated Input Voltage		620V		
Max. Input Current	40A + 2*32A			40A + 3*32A
Max. Short Circuit Current	50A + 2*45A			50A + 3*45A
Start Input Voltage		200V		
MPPT Operating Voltage Range		180V-1000V		
Max. Number of PV Strings	2/2/2			2/2/2/2
No. of MPPTs	3			4
<b>Output (Grid)</b>				
Rated AC Active Power	30,000W	40,000W	50,000W	60,000W
Max. AC Apparent Power	33,400VA	44,500VA	55,600VA	66,700VA
Max. AC Active Power (PF=1)	33,400W	44,500W	55,600W	66,700W
Max. AC Output Current	51A	67.5A	84.3A	3*92A
Rated AC Voltage		380V / 400V / 415V, 3P+N+PE or 3P+PE		
AC Voltage Range <sup>①</sup>		320V-520V (Adjustable)		
Rated Grid Frequency		50Hz / 60Hz		
Grid Frequency Range <sup>②</sup>		45Hz-55Hz / 55Hz-65Hz (Adjustable)		
THDI		<3%@Rated Power		
DC Current Injection		<0.5%@Rated Current		
Power Factor		>0.99 Rated power (Adjustable 0.8 LD - 0.8 LG)		
<b>Protection</b>				
DC Switch		Support		
Anti-Islanding Protection		Support		
AC Overcurrent Protection		Support		
AC Short Circuit Protection		Support		
DC Reverse Connection		Support		
Surge Arrester		AC Type II / DC Type II		
Insulation Resistance Detection		Support		
Leakage Current Protection		Support		
<b>General</b>				
Topology		Transformerless		
IP Rating		IP66		
Night Self Consumption		<5W (Standard)		
Cooling		Fan Cooling		
Operating Temperature Range		-25°C to 60°C		
Relative Humidity Range		0-100%		
Max. Operating Altitude		4000m		
Dimensions (W*H*D)		635mm*530mm*224mm		
Weight	36Kg	40Kg	42Kg	43.5Kg
<b>HMI &amp; COM</b>				
Display		Wireless & App + LED, LCD (Optional)		
Communication		RS485, Optional: WiFi / GPRS		
<b>Certification</b>				
Safety		IEC62109, IEC61727, IEC62116		
Grid Code		IEC61683, IEC60068, IEC61000		